

Digitally reproduced from original Army documents

The Saladin armoured car (FV601) was a six-wheeled vehicle carrying a crew of 3. The driver was accommodated in the hull with the commander and gunner in the turret. It was armed with a 76mm gun, a .30in Browning coaxial machine gun and a separate, dismountable, .30in Browning machine gun used for anti-aircraft and general defence.

It was powered by a Rolls-Royce B80 5.7 litre 8 cylinder petrol engine driving all six wheels via a torque converter and pre-select gearbox.

The Saladin was used by various countries including Australia, Germany, Honduras, Indonesia, Jordan, Kuwait, Lebanon, Oman, Portugal, Sudan, Tunisia, Yemen and UK.

The User Handbook is in English and comprises 269 pages covering vehicle operation, maintenance and fault diagnosis. There are 69 colour and monochrome illustrations including hydraulic schematics and vehicle wiring diagrams.



## Contents

1. Data
2. Hull and Turret details
3. Fire Fighting Equipment
4. Engine, lubrication and cooling system
5. Fuel system and carburetter
6. Ignition
7. Charging, lighting, starting, electrical accessories
8. Fluid coupling, gearbox and transfer box
9. Bevel boxes, prop shafts, tracta joints
10. Suspension and road wheels
11. Hydraulic system
12. Steering
13. Brakes
14. Hints and tips on driving
15. Towing
16. Diagnosis of faults
17. Parade servicing
18. Tools, spares and stowage



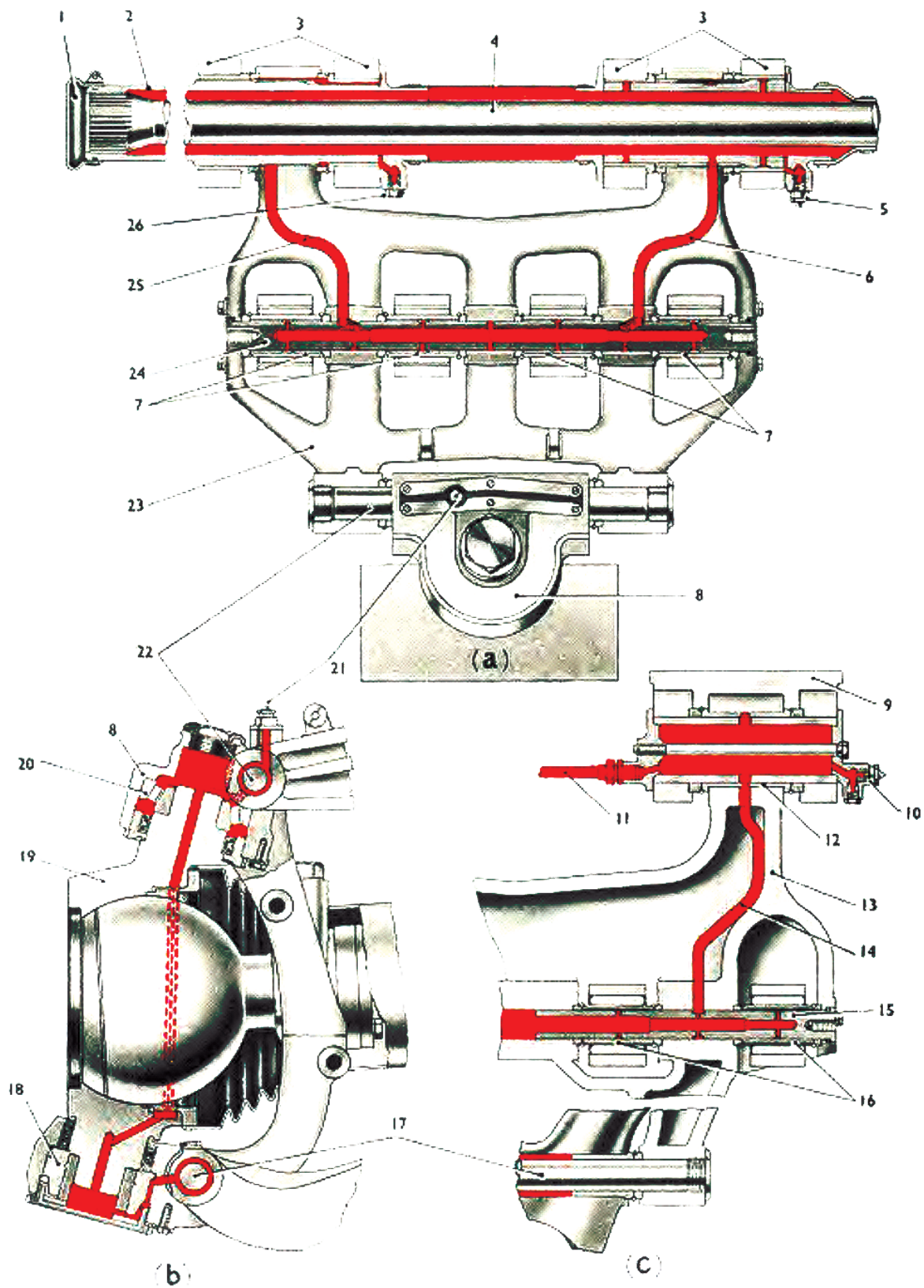

1H 7765

Fig 57 Suspension unit lubrication system

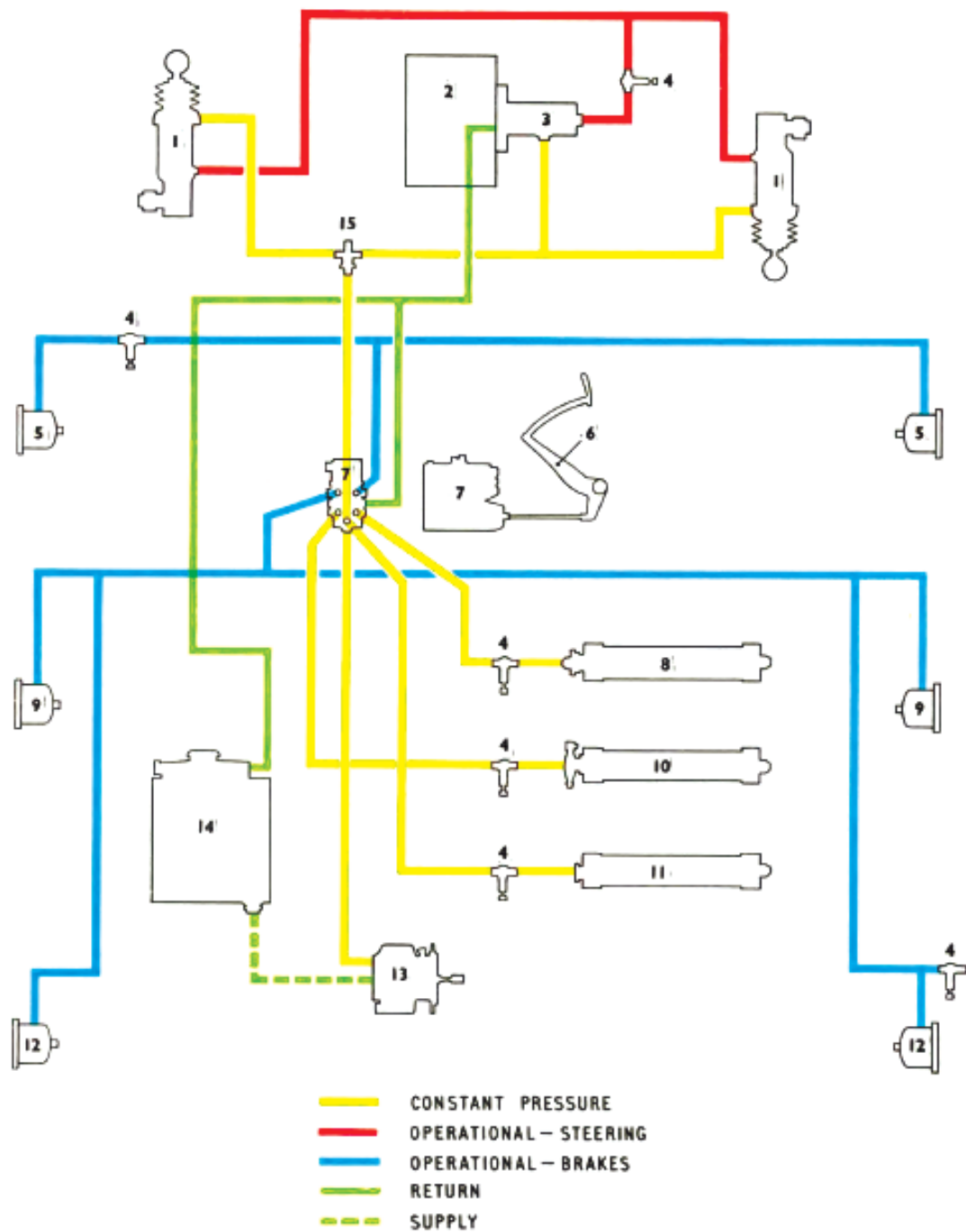

187704

- |                                        |                                         |
|----------------------------------------|-----------------------------------------|
| 1 Steering jack (2)                    | 9 Brake operating cylinder - centre (2) |
| 2 Steering box                         | 10 Accumulator - centre and rear brakes |
| 3 Steering control valve               | 11 Accumulator - steering               |
| 4 Check point (6)                      | 12 Brake operating cylinder - rear (2)  |
| 5 Brake operating cylinder - front (2) | 13 Hydraulic fluid pump                 |
| 6 Footbrake pedal                      | 14 Fluid supply tank                    |
| 7 Twin power valve and cut-out         | 15 Restrictor valve                     |
| 8 Accumulator - front brakes           |                                         |

Fig 59 Hydraulic braking and steering system